

S4K2U-5C Series Industrial On-Line UPS

230 V, 1000 VA–3000 VA User Manual



While every precaution has been taken to ensure accuracy and completeness in this manual, EGS Electrical Group, LLC. assumes no responsibility, and disclaims all liability for damages resulting from use of this information or for any errors or omissions.

The SolaHD and Emerson logos are registered in the U.S. Patent and Trademark Office. All other product or service names are the property of their registered owners.

©2012 EGS Electrical Group, LLC. All rights reserved. Specifications are subject to change without notice.

Contents

Important Safety Precautions	6
Save these Instructions	6
Battery Safety Notes	7
Electromagnetic Compatibility	7
Information for the Protection of the Environment	7
Glossary of Symbols	8
1.0 Product Description	9
1.1 Features	9
1.2 Available Models.	9
1.3 Appearance & Components	10
1.3.1 Front Panel & Controls	10
1.3.2 Rear Panel Features	10
1.4 Major Components	12
1.4.1 Surge Protection Device (SPD) & EMI/RFI Filters	12
1.4.2 Rectifier/Power Factor Correction (PFC) Circuit	12
1.4.3 Inverter	13
1.4.4 Battery Charger	13
1.4.5 Dc-to-Dc Converter	13
1.4.6 Battery	13
1.4.7 Dynamic Bypass	13
1.5 Operating Modes	13
1.5.1 Mains (V ac) Mode.	13
1.5.2 Manual Bypass Mode	13
1.5.3 Battery Mode	14
1.5.4 Battery Recharge Mode	14
1.5.5 Frequency Converter Mode	14

2.0 Installation	15
2.1 Unpacking & Inspection	15
2.2 What's Included	15
2.3 Preparation for Installation	15
2.3.1 Installation Environment.	15
2.3.2 Installation Clearances.	15
2.4 Mechanical Installation.	16
2.4.1 Tower Installation	16
2.4.2 Rack Installation.	18
2.5 Cable Connection	21
2.5.1 Connecting Input Plug & Loads.	21
2.5.2 Ac Input/Output Hardwire Installation	22
2.5.3 Connecting Battery Cables.	25
2.6 Connecting Communication Cables	25
2.6.1 Connecting USB Communication Cables	25
2.6.2 Installing the IntelliSlot Card & Communication Cables	25
3.0 Control & Indicators	26
3.1 Control Buttons	26
3.1.1 On/Alarm Silence/Manual Battery Test Button	26
3.1.2 Standby/Manual Bypass Button	27
3.2 Indicators	27
3.2.1 Battery Level Indicators	27
3.2.2 Load Level Indicators	28
3.2.3 UPS Status Indicators	28
4.0 Operation	29
4.1 Startup Checklist for the S4K2U-5C	29
4.2 Starting the UPS	29
4.3 Manual Battery Test	29
4.4 Manual Bypass.	30
4.5 Shut Down the S4K2U-5C	30
4.6 Disconnecting Input Power from the S4K2U-5C	30

5.0 Communication	31
5.1 IntelliSlot Communication Cards	31
5.1.1 MultiLink	31
5.2 USB Port Communication	31
5.2.1 Configuration Program	32
5.3 Terminal Block Communication.	33
5.3.1 Any Mode Shutdown	33
5.3.2 Battery Mode Shutdown.	33
5.3.3 On Battery.	34
5.3.4 Low Battery	34
6.0 Battery Cabinet	35
7.0 Maintenance	36
7.1 Replacing the Internal Battery Pack	36
7.1.1 Battery Replacement Procedures.	36
7.3 Precautions	38
7.4 Checking UPS Status.	38
7.5 Checking UPS Functions	38
8.0 Troubleshooting	39
8.1 UPS Symptoms	39
8.1.1 Indicators	39
8.1.2 Audible Alarm	40
8.2 Troubleshooting	40
9.0 Specifications	42
10.0 Warranty & Support	45
10.1 Warranty Information	45
10.2 Technical Support	45

IMPORTANT SAFETY PRECAUTIONS

WARNING

Observe all cautions and warnings in this manual. Failure to do so may result in serious injury or death.

Refer all UPS and battery service to properly trained and qualified service personnel. Do not attempt to service this product yourself and never work alone.

Opening or removing the cover may expose you to lethal voltages within this unit, even when it is apparently not operating and the input wiring is disconnected from the electrical source.

SAVE THESE INSTRUCTIONS

This manual contains important safety instructions that must be followed during the installation and maintenance of the UPS and batteries. Read this manual thoroughly before attempting to install or operate this UPS.

This UPS contains no user-serviceable parts except the internal battery pack. The Off/Bypass push button does not electrically isolate internal parts. Under no circumstances should you attempt to gain internal access other than to replace the batteries due to risk of electric shock or burn. Do not continue to use the UPS if the front panel indicators are not in accordance with these operating instructions or if the UPS performance alters in use. Refer all faults to your local distributor, SolaHD representative or SolaHD Technical Support.

This UPS has an internal battery, and the output receptacles of the UPS may carry live voltage even if the UPS is not connected to mains input power.

Before moving or rewiring this UPS, disconnect mains input power and the battery and make sure that the UPS is completely shut down. Otherwise, the output terminal may carry live voltage, presenting an electric shock hazard.

To ensure human safety and normal UPS operation, the UPS must be properly grounded before use.

When the UPS is connected to an IT power distribution system, a short-circuit protection device must be installed on the neutral line.

Install and use the S4K2U-5C in the following environments:

- Temperature: 0°C – 40°C (32°F – 104°F); Relative humidity: 0% – 95%, non-condensing
- Out of direct sunlight
- Away from heat sources
- Stable surface, not subject to vibrations or shocks
- Away from dust and other particulates
- Away from corrosive substances, salts and flammable gases

Keep the air inlet and outlet of this UPS unobstructed. Poor ventilation will increase the internal temperature of the UPS and can adversely affect the UPS and its batteries.

Keep liquid and foreign objects away from the UPS.

In case of fire, use a dry chemical fire extinguisher to put out the fire. Using a fluid fire extinguisher may cause electric shock.

This UPS is not intended for use with life support and other designated critical devices. Maximum load must not exceed that shown on the UPS rating label. This UPS is designed for data processing equipment. If uncertain, consult your local dealer or SolaHD representative.

Battery Safety Notes

CAUTION

Do not dispose of batteries in a fire; they may explode. Dispose of used batteries according to local regulations.

Do not open or mutilate the batteries. Released electrolyte is toxic and harmful to skin and eyes. If electrolyte comes into contact with the skin, wash the affected area immediately and get medical attention.

CAUTION

A battery can present a risk of electrical shock and high short-circuit current. The following precautions should be observed when working with batteries:

- Remove watches, rings, and other metal objects.
- Use tools with insulated handles.
- Wear rubber gloves, boots, and safety glasses.
- Do not lay tools or metal parts on top of batteries.
- If the battery pack is damaged in any way or shows signs of leakage, please contact your SolaHD representative immediately.
- Disconnect charging source prior to connecting or disconnecting battery terminals
- Determine if the battery is inadvertently grounded. If it is inadvertently grounded, remove the source of the ground. Contact with any part of a grounded battery can result in electrical shock. The likelihood of such shock will be reduced if grounds are removed during installation and maintenance (applicable to a UPS and a remote battery supply not having a grounded supply circuit).

Electromagnetic Compatibility

The S4K2U-5C complies with the limits for a CLASS A DIGITAL DEVICE, PURSUANT TO Part 15 of FCC rules. Operation is subject to the following two conditions: (1) This device may not cause harmful interference and (2) This device must accept any interference received, including interference that may cause undesired operation. Operating this device in a residential area is likely to cause harmful interference that users must correct at their own expense.

The S4K2U-5C Series complies with the requirements of EMC Directive 2004/108/EC and the published technical standards. Continued compliance requires installation in accordance with these instructions and use of accessories approved by SolaHD.

Information for the Protection of the Environment







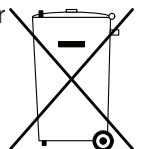







UPS Servicing: The UPS makes use of components dangerous for the environment (e.g. batteries, electronic cards, and electronic components). The components removed must be taken to specialized collection and disposal centers.

Notice to European Union Customers—Disposal of Old Appliances: This product has been supplied from an environmentally aware manufacturer that complies with the Waste Electrical and Electronic Equipment (WEEE) Directive 2002/96/CE.

The crossed-out-wheellie-bin symbol (at right) is placed on this product to encourage you to recycle whenever possible. Please be environmentally responsible and recycle this product through your recycling facility after the product's end of life. Do not dispose of this product as unsorted municipal waste. Follow local municipal waste ordinances for proper disposal provisions to reduce the environmental impact of Waste Electrical and Electronic Equipment (WEEE).



Glossary of Symbols

	Risk of electrical shock
	Indicates caution followed by important instructions
	Ac input
	Ac output
	Requests the user to consult the manual
	Indicates the unit contains a valve-regulated lead acid battery
	Recycle
	Dc voltage
	Equipment grounding conductor
	Bonded to ground
	Ac voltage
	ON/Alarm Silence/Battery Test
	OFF/Bypass
	WEEE

1.0 Product Description

The SolaHD S4K2U-5C Series is a compact, on-line uninterruptible power system (UPS) that continuously conditions and regulates its output voltage. It is designed to supply microcomputers and other sensitive equipment with clean sine wave input power.

Upon generation, ac power is clean and stable. However, during transmission and distribution it is subject to voltage sags, spikes and complete failure that may interrupt computer operations, cause data loss and damage equipment. The S4K2U-5C protects equipment from these disturbances. The S4K2U-5C continuously charges its batteries from mains power, enabling it to supply power to connected loads even when mains power fails.

This sections describes the UPS, its features, models, appearance, components, operating principles, and operating mode.

1.1 Features

The UPS includes the following features:

- Intelligent battery management to extend the battery life
- Operation and display panel with LED for monitoring load percentage and battery capacity independently
- Flexible network management with MultiLink™ software
- Fan fault self-inspection and automated diagnostic function
- Intelligent fan operation, automatically changing rotation speed depending on system requirements to decrease power consumption and noise
- Input circuit breaker to ease recovery from overloads
- CE mark and safety approval from CE
- Communication options: USB port, IntelliSlot® port, and terminal block communication
- Dry contacts for remote monitoring
- Input power factor greater than 0.99 at 100% load
- Output voltage selection function using the configuration software

1.2 Available Models

Available models of the UPS are shown in Table 1:

Model	Nominal Power Rating
S4K2U1000-5C	1000 VA/900 W
S4K2U2000-5C	2000 VA/1800 W
S4K2U3000-5C	3000 VA/2700 W

1.3 Appearance & Components

1.3.1 Front Panel & Controls

The SolaHD S4K2U-5C rack/tower models, in various power ratings, have the same general appearance, controls, and features (see Figure 1). The various rack/tower models differ largely in the receptacle type.

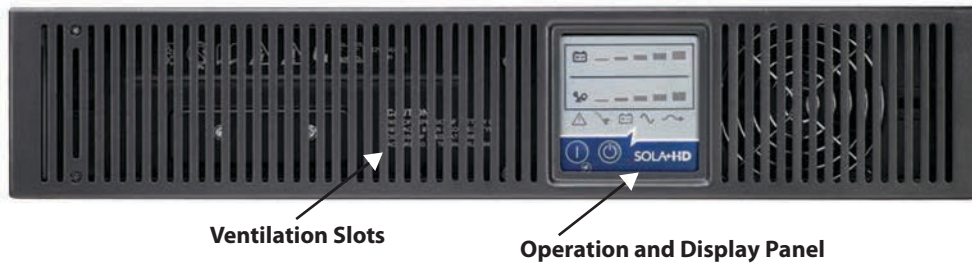

Figure 1: S4K2U-5C rack/tower models—front view

1.3.2 Rear Panel Features

The rear panel of the S4K2U-5C has these features (see Figure 2):

- USB port
- Cooling fan
- Input receptacle
- Output receptacles
- Input circuit breaker
- IntelliSlot port
- Communication terminal block

1000 VA models

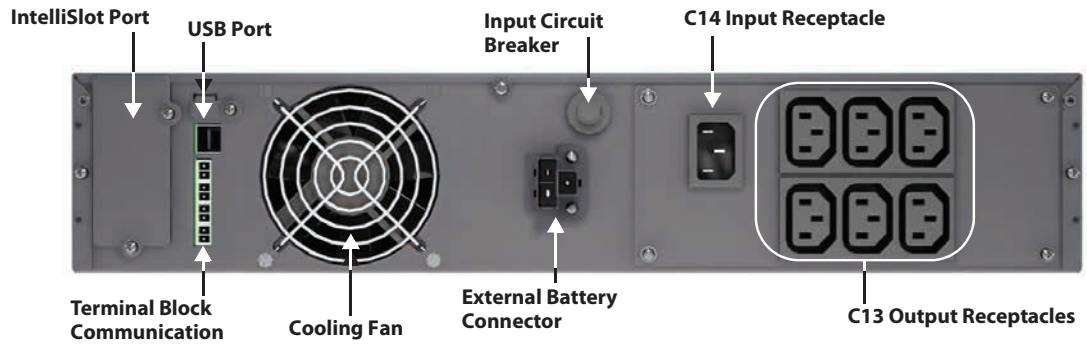

2000 VA models

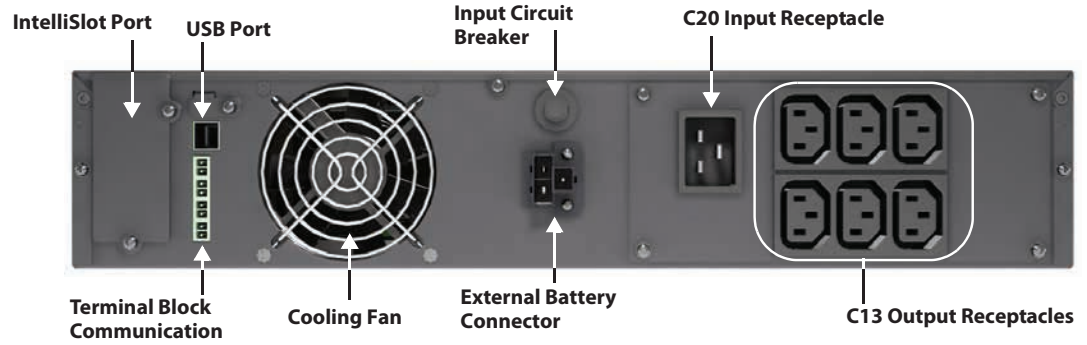

3000 VA models

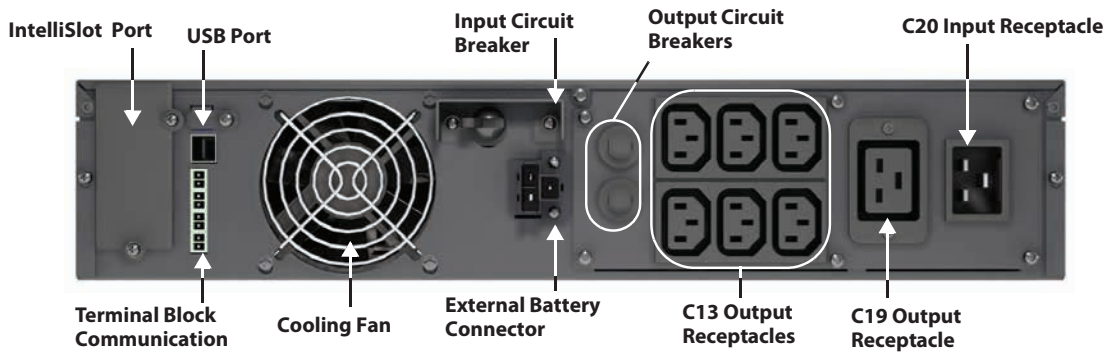

Figure 2: S4K2U-5C 230 V rack/tower models—rear panel components

1.4 Major Components

The operating principle of the UPS is illustrated in Figure 3.

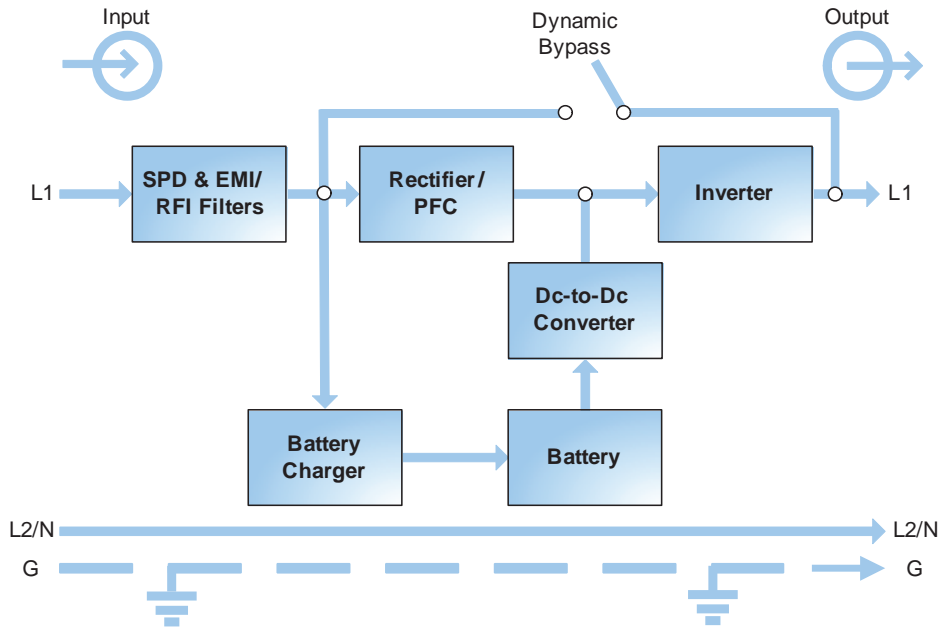

Figure 3: Operating principle diagram

The UPS is composed of mains input, SPD and EMI/RFI filters, rectifier/PFC, inverter, battery charger, dc-to-dc converter, battery, dynamic bypass, and UPS output.

1.4.1 Surge Protection Device (SPD) & EMI/RFI Filters

The S4K2U-5C has surge protection and filters that protect the connected load from power surges, electromagnetic interference (EMI), and radio frequency interference (RFI). These features can minimize any surges or interference present in the mains power. The filters also prevent surges or interference generated by the UPS from adversely affecting devices connected on the same branch as the UPS.

1.4.2 Rectifier/Power Factor Correction (PFC) Circuit

In normal operation, the S4K2U-5C's rectifier/power factor correction (PFC) circuit converts mains power to regulated dc power for use by the inverter, while ensuring that the wave shape of the input current used by the UPS is near ideal. Extracting this sine wave input current achieves two objectives:

- Efficient power use by the UPS
- Reduced reflected harmonics

This results in cleaner power being available to other devices in the building not protected by the S4K2U-5C.

1.4.3 Inverter

In normal operation, the S4K2U-5C's inverter utilizes the dc output of the PFC rectifier to produce precise, regulated sine wave ac power. When mains power fails, the inverter receives dc power from the dc-to-dc converter. In either operation mode, the UPS inverter is on-line, continuously generating clean, precise, regulated ac output power.

1.4.4 Battery Charger

The battery charger utilizes energy from the mains power and precisely regulates it to continuously float charge the batteries. The batteries are being charged whenever the S4K2U-5C is plugged in, even when the UPS is not turned on.

1.4.5 Dc-to-Dc Converter

The dc-to-dc converter raises the dc voltage from the battery to the optimum operating voltage for the inverter. This allows the inverter to operate continuously at its optimum efficiency and voltage, thus increasing reliability.

1.4.6 Battery

The S4K2U-5C uses valve-regulated, non-spillable, lead acid batteries. To maintain battery design life, operate the UPS in an ambient temperature of 0°C to 25°C (32°F to 77°F).

NOTE: Optional external battery cabinets are available to extend battery run times.

1.4.7 Dynamic Bypass

The S4K2U-5C provides an alternate path for mains power to the connected loads in the unlikely event of a UPS malfunction. Should the S4K2U-5C have an overload, overtemperature, or UPS failure condition, the UPS automatically transfers the connected loads to bypass.

NOTE: The bypass power path does not protect the connected loads from disturbances on the mains.

1.5 Operating Modes

The UPS operating modes include: Mains (V ac) Mode, Bypass Mode, Battery Mode, Battery Recharge Mode, and Frequency Converter Mode. For descriptions of indicators and control buttons, refer to "3.0 Controls & Indicators".

1.5.1 Mains (V ac) Mode

During Mains (V ac) Mode, mains power provides energy to the S4K2U-5C. The filters, PFC rectifier, and the inverter process this power to provide computer-grade power to connected loads. Meanwhile, the UPS maintains the batteries in a fully charged state.

1.5.2 Manual Bypass Mode

Manual Bypass Mode occurs when the Standby/Manual Bypass button is pressed and held for about 2 seconds while the S4K2U-5C is in Mains (V ac) Mode. Bypass operation is indicated by an audible alarm and illuminated amber bypass indicator. (If other indicators are illuminated, refer to "8.0 Troubleshooting"). During Manual Bypass Mode, mains power bypasses the inverter and provides energy to the connected load.

CAUTION

Turning off the UPS in Manual Bypass Mode will result in loss of output power and dropped loads.

1.5.3 Battery Mode

The S4K2U-5C enters Battery Mode when mains power fails or is outside acceptable values. The battery system supplies power through the dc-to-dc converter to the inverter to generate clean ac power for the connected loads.

When the S4K2U-5C enters Battery Mode, the UPS sounds a half-second beep at 10-second intervals.

When approximately 2 minutes of run time remains, the beeps sound every 5 seconds to warn that the battery is getting low (this low battery warning is user-configurable).

In Battery Mode, the Ac Input indicator goes off and the Battery Level indicators illuminate. Each Battery Level indicator represents a 20% capacity level. As capacity decreases, fewer indicators remain illuminated. Refer to “8.0 Troubleshooting”.

For approximate battery run times, refer to “9.0 Specifications—Table 14”. The times in Table 14 are approximate. They are based on resistive loads and an ambient temperature of 25°C (77°F). To increase this time, turn off non-essential loads (such as idle computers and monitors) or add optional external battery cabinets.

CAUTION

Turning off the S4K2U-5C while in Battery Mode will result in loss of output power. If the UPS is turned off manually, it must be manually restarted after mains power returns. If the UPS is turned off by a communication signal or because the batteries are depleted, it will operate as selected in the configuration program for Auto-Restart (refer to “5.2.1 Configuration Program”).

1.5.4 Battery Recharge Mode

Once mains power is applied to the S4K2U-5C, the battery charger begins charging the batteries.

1.5.5 Frequency Converter Mode

All models of the S4K2U-5C are capable of frequency conversion. Frequency Conversion Mode can be selected using the configuration program. Allowable frequency operating modes include:

- Auto Sensing — 50 Hz or 60 Hz — Bypass Enabled
- Auto Sensing — 50 Hz or 60 Hz — Bypass Disabled
- Frequency Converter — 50 Hz — Bypass Disabled
- Frequency Converter — 60 Hz — Bypass Disabled

NOTE: The default for all models of the S4K2U-5C is “Auto Sensing — 50 Hz or 60 Hz — Bypass Enabled.”

CAUTION

Do not touch the ac input receptacle when the UPS is operating. Ac input voltages may still be present, even when the ac input indicator is off.

2.0 Installation

2.1 Unpacking & Inspection

Unpack the UPS and conduct the following checks:

- Inspect the UPS for shipping damage. If any shipping damage is found, report it to the carrier and your local dealer or SolaHD representative immediately.
- Check the accessories against the delivery list. If there are any discrepancies, contact your local dealer or SolaHD representative immediately.

2.2 What's Included

- Compact disk containing: MultiLink, configuration program, and user manual
- One USB cable, 2 m (6-1/2 ft.) long
- **1000 VA Models:**
Two, 10 A IEC C13 C14 output cables, 2 m (6-1/2 ft.) long
- **2000 VA – 3000 VA Models:**
Three, 10 A IEC C13 C14 output cables, 2 m (6-1/2 ft.) long
One, CEE 7/7 (Schuko) to IEC C20 input cable, 2.5 m (8-1/5 ft.) long
One, BS1363 (UK) to IEC C20 input cable, 2.5 m (8-1/5 ft.) long.
- Mounting hardware, including screws and handles
- Two plastic tower stand sets (four pieces total)
- Terminal block communication terminals
- Warnings, Safety Instructions booklet, and WEEE recycling sheet (ISO 14001 compliance)

NOTE: The S4K2U-5C external battery cabinet shipping package includes one battery cabinet, two spacers for tower configuration, and one dc power cable.

2.3 Preparation for Installation

2.3.1 Installation Environment

- Install the UPS indoors in a controlled environment, where it cannot be accidentally turned off. The installation environment should meet the specifications listed in "9.0 Specifications".
- Place the UPS in an area of unrestricted airflow around the unit, away from water, flammable liquids, gases, corrosives, and conductive contaminants. Avoid direct sunlight.

NOTE: Operating the UPS in temperatures above 25°C (77°F) reduces battery life.

2.3.2 Installation Clearances

Maintain at least 100 mm (4 inches) clearance in the front and rear of the UPS. Do not obstruct the air inlets on the front panel and rear panel of the UPS; blocking the air inlets reduces ventilation and heat dissipation, shortening the service life of the unit.

2.4 Mechanical Installation

The S4K2U-5C may be installed as a tower or in a rack, depending on space and use considerations. The S4K2U-5C may be used alone, as a single UPS, or with up to four battery cabinets.

NOTE: When installing the UPS or making input/output connections, comply with all relevant safety codes and standards.

2.4.1 Tower Installation

To install the S4K2U-5C as a tower:

1. Take out support bases from the accessories (see Figure 4).

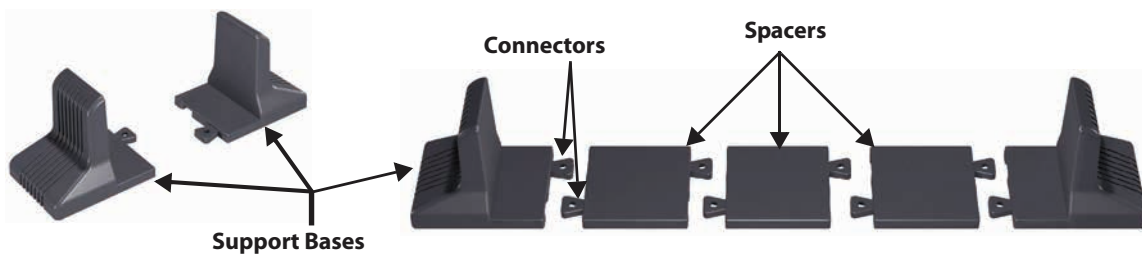

Figure 4: Support bases

2. If optional external battery cabinets will be connected to the UPS, take out the spacers shipped with the battery cabinet.
3. Connect the spacers and the support bases as shown in Figure 4. Each S4K2U-5C needs two assembled support bases, one in the front and one in the rear.
4. Adjust the direction of the operation and display panel on the S4K2U-5C.
 - a. Remove the front metal bezel cover as shown in Figure 5.



Figure 5: Remove the front metal bezel cover

- b. Using the finger grips on the display panel, gently pull and rotate 90 degrees clockwise and snap it back into position as shown in Figure 6.



Figure 6: Rotate the operation and display panel

- c. Replace the front metal bezel cover on the S4K2U-5C. At this point, the UPS operation and display panel has been rotated 90 degrees clockwise, which provides upright viewing for users.
5. Place the S4K2U-5C and any battery cabinets on the support bases. Each S4K2U-5C needs two support assemblies as shown in Figure 7.

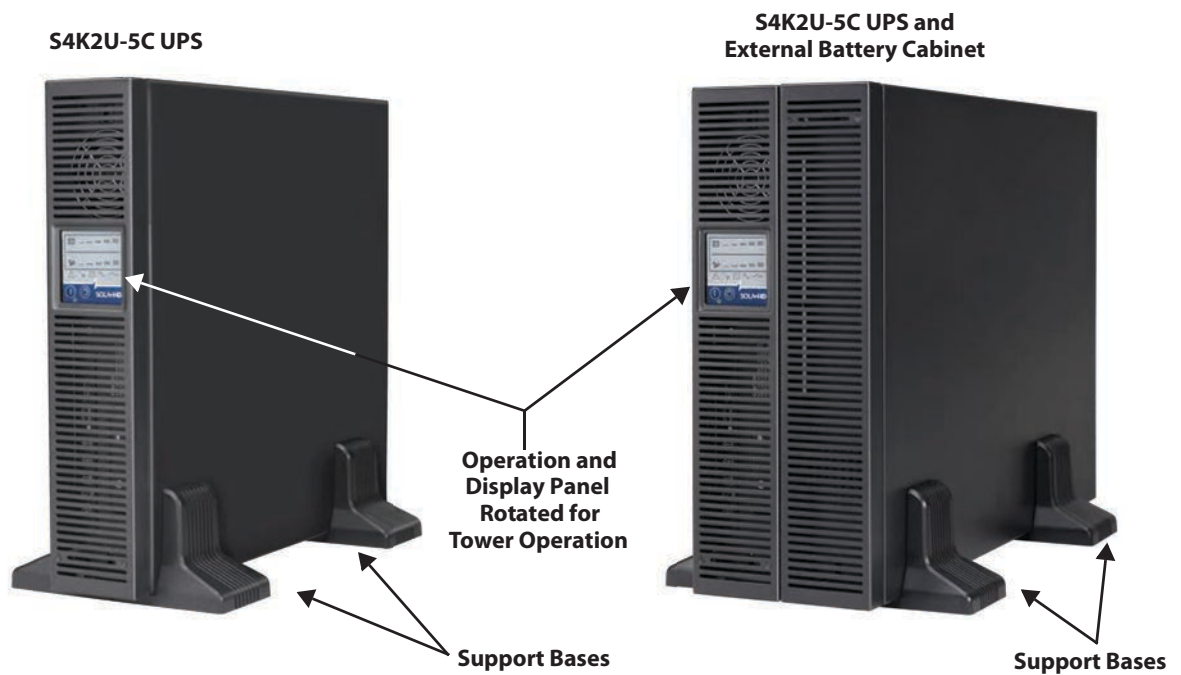

Figure 7: Tower installation

2.4.2 Rack Installation

NOTES:

- When the S4K2U-5C is installed in a rack, it must be supported by a shelf, brackets, or slide rails on each side. The factory-supplied ears cannot support the weight of the UPS. They are used to move the UPS into and out of the rack and to attach the UPS to the rack.
- Mounting hardware and slide rails are sold separately. Contact your local SolaHD representative for these options.

To install a S4K2U-5C in a rack:

1. Unpack the two bracket assemblies and mounting hardware from the rack-mounting kit (P/N: SRS1832). Bracket assembly includes inner member and front and rear members. They are interchangeable between left-hand or right-hand. Mounting hardware includes M4 screws and M5 screws.
2. Remove inner member of each bracket assembly by extending it to its outermost position, depressing the retaining latch and then pulling inner member from bracket assembly (see Figure 8).

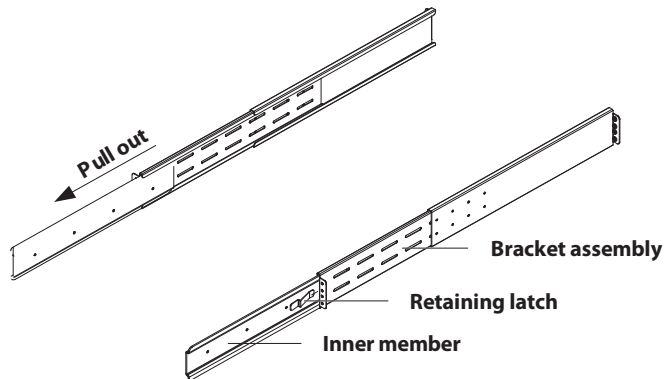

Figure 8: Pulling inner member from each bracket assembly

3. Determine the S4K2U-5C’s mounting position inside the racks vertical rails.

⚠ CAUTION

Install the S4K2U-5C as low as possible in the rack to reduce the risk of tipping.

4. Attach the rear member of each bracket assembly to the rack’s rails with two factory-supplied M5 screws (see Figure 9).

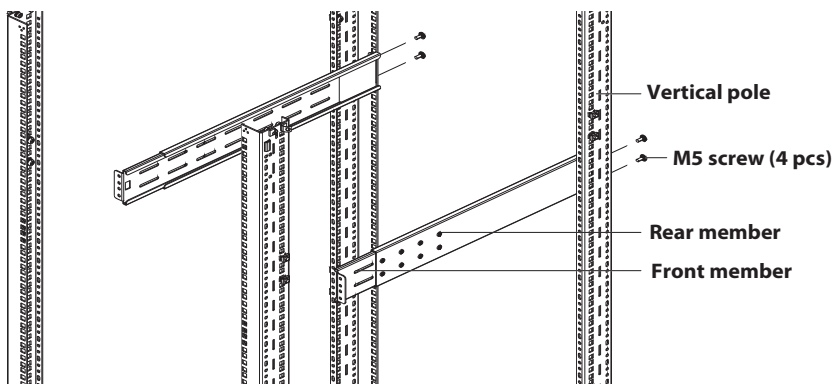

Figure 9: Installing rear member of each bracket assembly

5. Extend the bracket assembly by sliding the front member forward until it touches the rack's front vertical rails (adjustable length: 457–813 mm/18–32 in.). Use two M5 screws to fix each front member onto the front vertical rails through the installation holes. Make sure that bracket assemblies are at the same mounting height on all four rack rails, as shown in Figure 10.

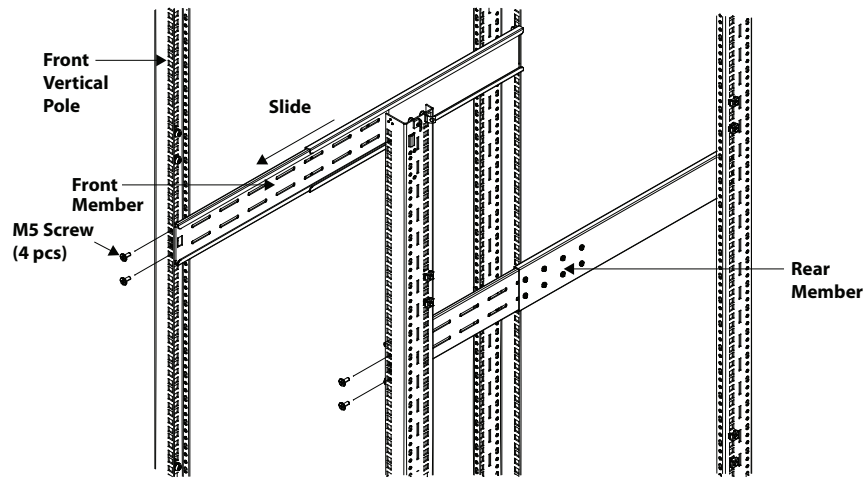

Figure 10: Installing front member of each bracket assembly

6. Fasten rear member and front member together using four M4 screws and four M4 nuts (M4 nuts have been installed on the rear member before delivery) per bracket assembly as shown in Figure 11.

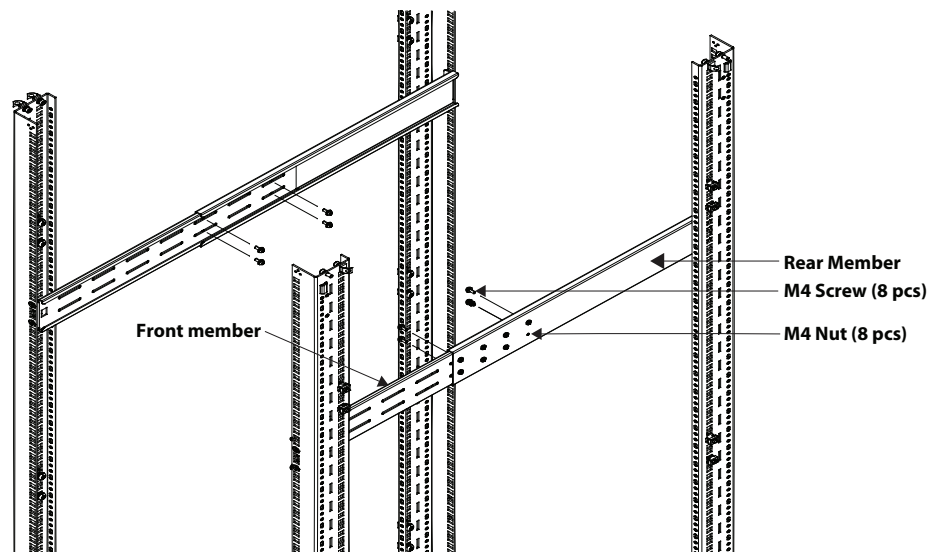

Figure 11: Fastening rear member and front member together

7. Fasten inner members (pulled from the bracket assemblies in Step 2) to both sides of the UPS with eight M4 screws provided in this kit. Make sure that the retaining latch is near the rear of the UPS as shown in Figure 12.

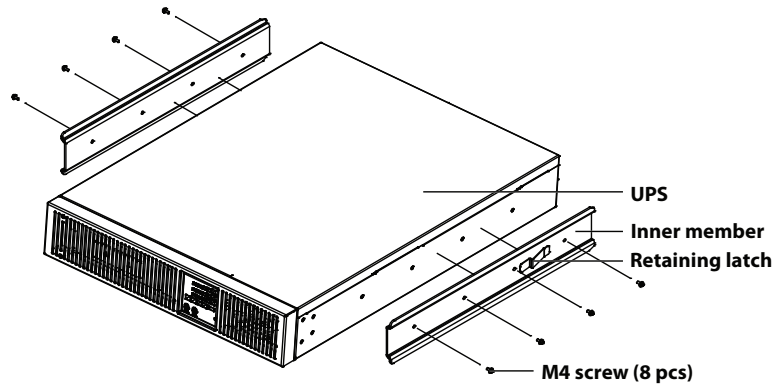

Figure 12: Installing inner members

8. Use M4 screws to install ears on both sides of the UPS as shown in Figure 13.

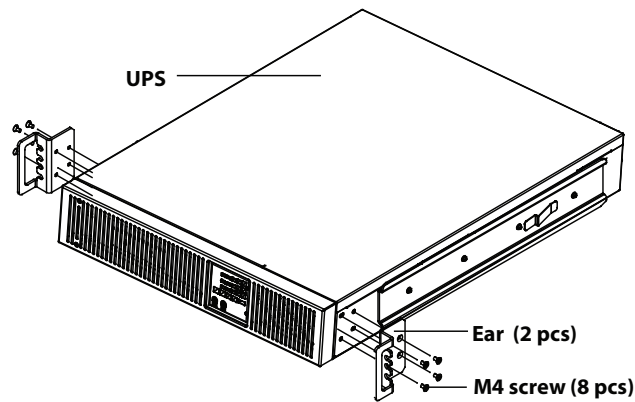

Figure 13: Installing ears

9. Insert the UPS, with inner members attached, into the bracket assemblies by inserting the top and bottom edges of the inner members into the top and bottom curved tracks of the front members. Slide the UPS into the rack as shown in Figure 14.

NOTE: The ends of the inner members are tapered to allow the rear of the UPS to be angled upward before insertion, if space allows. Do not use the factory supplied rack handles to lift the UPS; their intended use is to slide the UPS in and out of the rack.

NOTE: The UPS should move smoothly into the bracket assemblies. If not, recheck the alignment of the front and rear members from Steps 4 through 6.

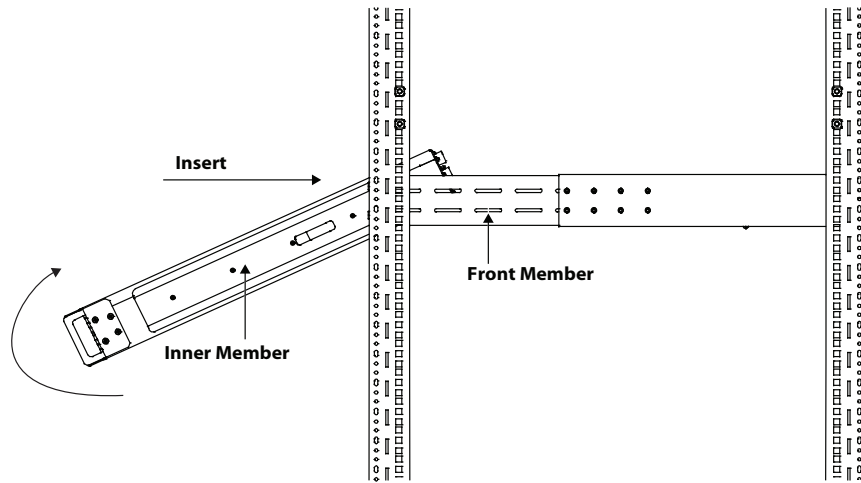

Figure 14: Insert the UPS

10. Through the ears, use M5 screws provided in this kit to secure the front of the UPS to the rack vertical rails to prevent the UPS from sliding out of position.
11. If optional external battery cabinets are connected to the UPS, they can be placed all on one side of the UPS or stacked beneath the UPS. The installation procedures are the same as those of the UPS.

NOTE: Up to four external battery cabinets can be connected to the S4K2U-5C. Each cabinet will increase the battery recharge time.

2.5 Cable Connection

The S4K2U-5C rear panel has input and output receptacles. Refer to “1.3.2 Rear Panel Features” for details. The battery cables are supplied with the battery cabinet.

2.5.1 Connecting Input Plug & Loads

NOTE: Ensure that all the loads are turned off. Prepare an input power supply that is properly protected by a circuit breaker in accordance with national and local electrical codes. The wall receptacle must be grounded. SolaHD recommends installing an upstream circuit breaker of the same series as the S4K2U-5C’s input circuit breaker. The upstream breaker should be the same or higher capacity than the UPS input circuit breaker.

The specification of input circuit breaker on the rear panel of UPS is shown in Table 2:

Table 2: Input Circuit Breaker Specification	
Model	Rated Circuit Breaker
S4K2U1000-5C	10 A
S4K2U2000-5C	16 A
S4K2U3000-5C	16 A

1. Plug all loads into the output receptacles on the rear panel of the S4K2U-5C.

NOTE: Distribute loads evenly across all receptacles to prevent overloading individual receptacles.

2. Plug the input receptacle of the S4K2U-5C into the input power connection.

2.5.2 Ac Input/Output Hardwire Installation

CAUTION

This installation must be performed by competent electrical personnel and wired in accordance with local and national electrical codes.

Installation Considerations:

On start-up, the UPS will take a half cycle inrush current of up to 3 times the rated current. This must be taken into account when selecting the overload protection device at the input mains supply distribution point. To avoid random tripping on startup, we recommend that the input mains supply be protected with a MCB (Mechanical Circuit Breaker) capable of withstanding this initial inrush.

The mains input supply cable must be connected to the UPS via a wall mounted double pole circuit breaker. The UPS output port must also be protected with a double pole circuit breaker connected to the load, rated to carry the input current, and be capable of breaking the maximum prospective short circuit current of this branch circuit. The breakers are to be mounted within six feet of the UPS and be readily accessible to the operator. Please refer to Table 3 for breaker specifications.

High quality ground (earth) connections are required for the equipment ground conductors (protective earth) and grounding electrode conductor (power system earth connection) to reduce electrical noise and provide for safe operation of the UPS and connected loads. Conduit used alone without a grounding conductor wire is not an acceptable connection. Size ground (protective earth) conductors equal to circuit conductors. For wiring information, please refer to Table 3.

Table 3: Overcurrent Protection & Wiring Specifications					
Model VA	Input Current Rating	Recommended External Overcurrent Protection	Recommended Wire (105°C Copper Wire)	Maximum Wire Accepted by Terminal Block	Terminal Tightening Torque
1000 VA	4.2 A	10 A	16 AWG/1.31 mm ²	8 AWG/8.36 mm ²	20 in.-lb./2.25 N-m
2000 VA	8.7 A	16 A	14 AWG/2.08 mm ²	8 AWG/8.36 mm ²	20 in.-lb./2.25 N-m
3000 VA	13.0 A	16 A	14 AWG/2.08 mm ²	8 AWG/8.36 mm ²	20 in.-lb./2.25 N-m

NOTES:

- Make sure the UPS is turned off and unplugged before removing the original cord/receptacle board. To install the cable box, the original cord/receptacle board must be removed and disconnected from the terminal block.
- The cable sizes and distribution methods used during installation are subject to local/national electrical codes of practice, and therefore are not detailed here. Table 3 details the standard current ratings. The UPS rating plate gives details of the current ratings for alternative output voltages.
- When choosing the input and output cables, users should strictly adhere to Table 3 for cable dimensions. Failure to observe Table 3 could result in personnel injury or damage to the UPS.
- When installing the cable box, make sure that the input and output cables do not interfere with the position the UPS or external battery connectors.
- User needs to supply hardware for securing input and output cables.
- Section 2.5.3 describes the connection of optional external batteries. Dc battery connections may not be hardwired. Safety/EMC certification requires that the supplied battery cable be used.

Installation procedures are as follows:

1. Remove the receptacle board on the UPS rear panel, as shown in Figure 15. Retain the six rear panel mounting screws for securing the box assembly to the UPS.

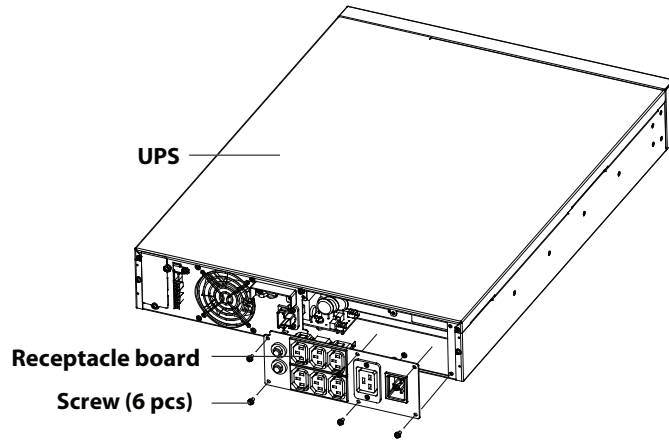

Figure 15: Removing the receptacle board

2. Take out the box assembly from the accessories and split it into cover, box, Base 1 and Base 2, as shown in Figure 16. Set the six screws aside for reassembly of the hardwire box.

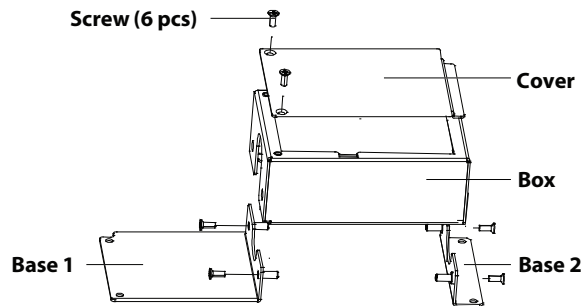

Figure 16: Splitting the box assembly

3. Use two rear panel mounting screws to install Base 1 to the UPS rear panel, as shown in Figure 17.

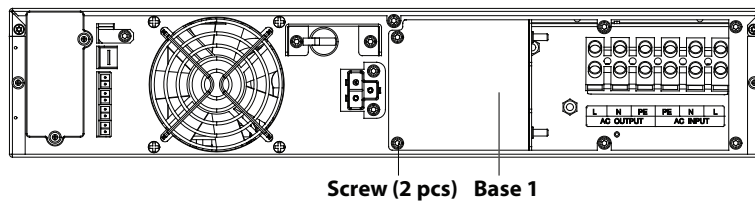

Figure 17: Installing Base 1

4. Connect the input power source line, neutral, and ground cables to the input line (L), neutral (N), and ground (PE) terminals on the UPS I/O terminal block and tighten the fixing screws (see Figures 18 and 19).
5. Connect the UPS output line, neutral and ground cables to the output line (L), neutral (N), and ground (PE) terminals on the UPS I/O terminal block and tighten the fixing screws (see Figures 18 and 19).

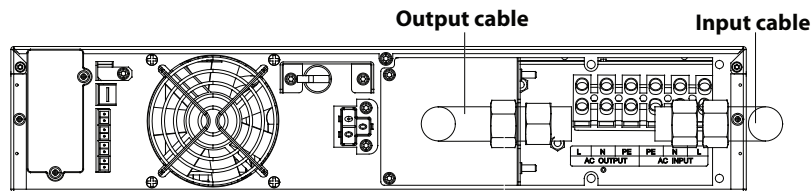

Figure 18: I/O Cable placement

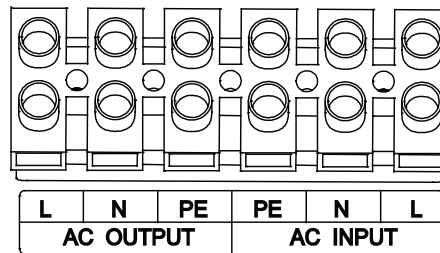

Figure 19: UPS I/O terminal block

6. Use two rear panel mounting screws to install Base 2 to the UPS rear panel, as shown in Figure 20.

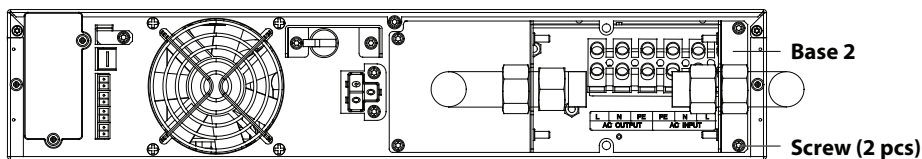

Figure 20: Installing Base 2

7. Insert the input and output cables/hardware into the slots on Base 2 and Base 1. Hand tighten the securing nuts to Base 2 and Base 1.
8. Set the box onto the Base 1 and Base 2 cable/hardware assemblies. Use the four box assembly screws to fasten the box to the bases (see Figure 21).
9. Using the hardware securing nuts, tighten the input and output cable assemblies to the box and bases (see Figure 21).

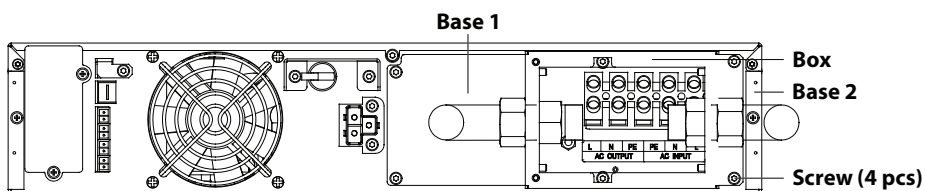

Figure 21: Installing the box

- Use two box assembly screws to install the cover onto the box, as shown in Figure 22.

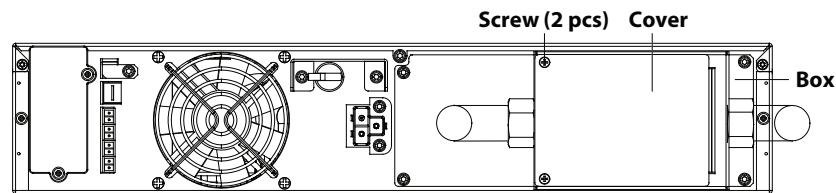

Figure 22: Installing the cover

- Connect the other end of the UPS output line, neutral, and ground cables to the load.

2.5.3 Connecting Battery Cables

- Switch off the input breaker of the battery cabinet.
- Take out the battery cable included with the battery cabinet.
- Connect one end of the battery cable to the external battery connector on the rear panel of the UPS and connect the other end to any battery port on the rear panel of the battery cabinet.
- Switch on the battery breaker on the rear of the external battery cabinet.
- Use the Configuration Program included with the UPS to specify the number of external battery cabinets connected to the S4K2U-5C. See Table 14 for approximate battery run times.

2.6 Connecting Communication Cables

Communication cable connection includes: USB and option card cables.

2.6.1 Connecting USB Communication Cables

- Take the USB communication cables out of the accessories box.
- Insert one end of the USB communication cable into the USB port on the rear panel of the S4K2U-5C (see Figure 2).
- Insert the other end of the USB communication cable into the USB port of the computer.

2.6.2 Installing the Optional IntelliSlot Card & Communication Cables

- Remove the protective cover of the IntelliSlot port on the S4K2U-5C and set it aside.
- Insert the IntelliSlot card into the IntelliSlot port and secure it with screws.
- To connect any cable associated with a IntelliSlot card, refer to the user manual provided with the card.

To configure and use the IntelliSlot communication card, refer to the card's user manual.

3.0 Control & Indicators

The operation and display panel, shown in Figure 23, is on the front panel of the S4K2U-5C.

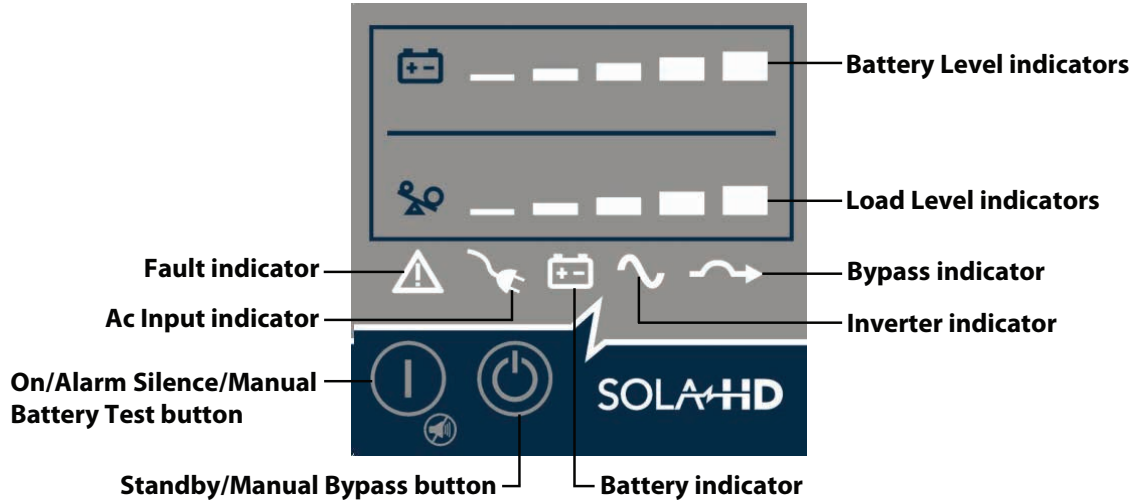

Figure 23: Operation and display panel

3.1 Control Buttons

The operation and display panel has two control buttons: On/Alarm Silence/Manual Battery Test and Standby/Manual Bypass.

3.1.1 On/Alarm Silence/Manual Battery Test Button

The On/Alarm Silence/Manual Battery Test button controls output power to connected load(s) and has three functions (see Table 4).

Table 4: Functions of the On/Alarm Silence/Manual Battery Test Button		
Function	Operation	Description
On	Press the button once for 3 seconds	To start the UPS
Alarm Silence ¹	Press the button for at least half a second	To silence the alarms ²
Manual Battery Test	Press the button for at least half a second while operating in Mains (V ac) Mode with no alarms present	To initiate a manual battery test

¹The low battery and bypass reminder alarms cannot be silenced
²After the alarm is silenced, the UPS will reactivate the alarm system to alert of additional problems

3.1.2 Standby/Manual Bypass Button

The Standby/Manual Bypass button controls output power to connected load(s) and has two functions (see Table 5).

Table 5: Functions of Standby/Manual Bypass Button		
Function	Operation	Description
Manual Bypass	Press the button once and hold it for about 2 seconds ³	To initiate a manual transfer of the connected loads to the internal bypass, if available
Standby	Press the button twice within 4 seconds (hold for at least a half a second each time) while the UPS is in Manual Bypass or Battery Mode ⁴	To shutdown the UPS and shut off all power to the connected loads

³If the bypass is not available due to voltage or frequency, pressing this button once will be ignored
⁴Perform all necessary shutdown procedures on connected loads before turning off the UPS

3.2 Indicators

The operation and display panel has seven indicators (see Figure 23). The indicators can be divided into two groups according to the applications: level indicators and UPS status indicators.

3.2.1 Battery Level Indicators

The Battery Level indicator is composed of five sets of LED bars that illuminate and flash to indicate the battery capacity level. The S4K2U-5C battery capacity level is shown in 20% increments (± 5%). The Battery Level indicators will illuminate as shown in Figure 24.

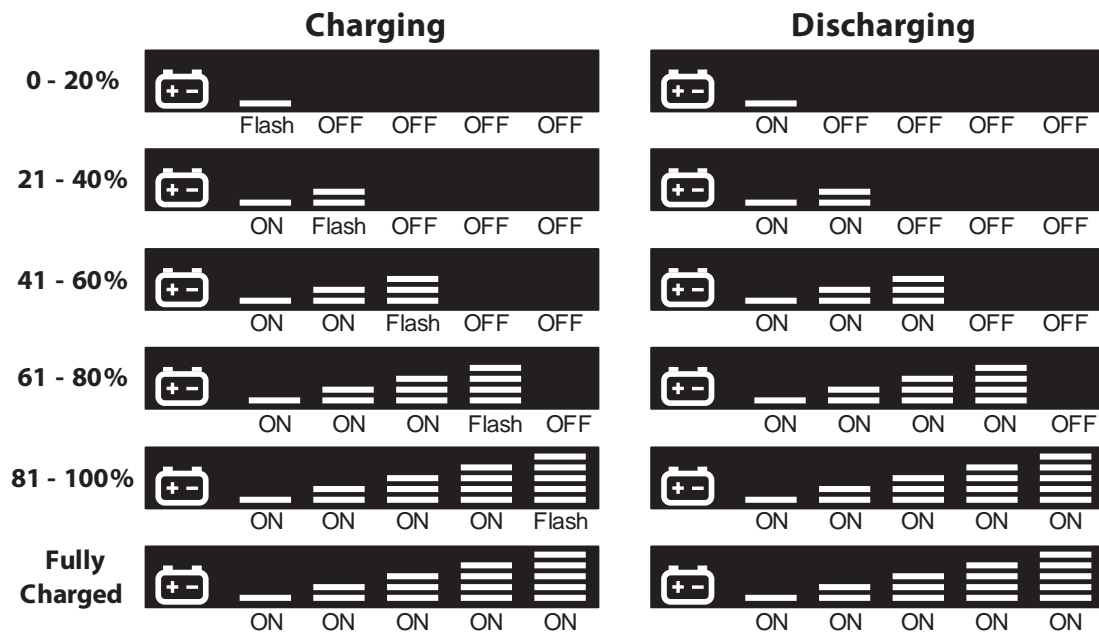

Figure 24: Battery Level indicators

3.2.2 Load Level Indicators

The Load Level indicator is composed of five LED bars that illuminate to indicate the relative load on the UPS output in 25% increments ($\pm 5\%$). The load level indicator will illuminate as shown in Figure 25.

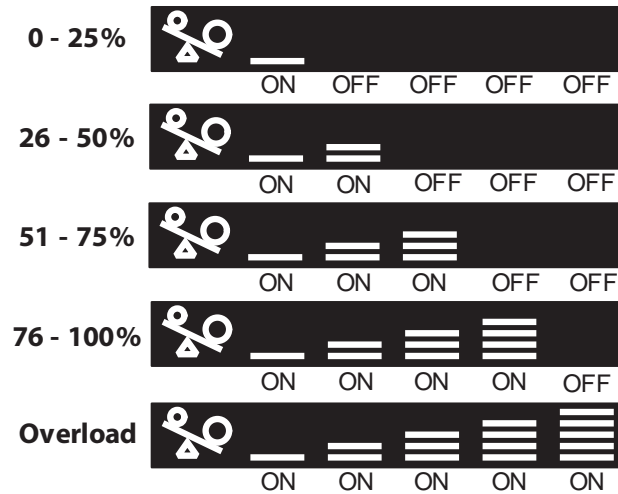

Figure 25: Load Level indicators

3.2.3 UPS Status Indicators

UPS status is indicated by five symbols: Fault indicator, Ac Input indicator, Battery indicator, Inverter indicator and Bypass indicator. Table 6 shows the symbols and their meanings.

Table 6: UPS Status Indicators			
UPS Status Indicator	Icon	Color	Description
Fault indicator		Red	On if the UPS has detected a fault; off if there is no fault
Ac Input indicator		Green	On when the mains input power is normal; off during mains failure; flashing when mains power is outside the specifications
Battery indicator		Amber	On when the battery is supplying power; off when the battery is not supplying power
Inverter indicator		Green	On when the inverter is supplying power; off when the inverter is not supplying power; and flashing when mains power is outside the specifications
Bypass indicator		Amber	On when the bypass is supplying power; off when the inverter is supplying power; and flashing when mains power is outside the specifications

4.0 Operation

This section describes checks to be made before starting the UPS, how to start the UPS, manual battery test, manual bypass, shutting down the UPS, and disconnecting the mains power from the UPS.

NOTE: The S4K2U-5C's battery is fully charged before delivery, but some charge will be lost during storage and shipping. To ensure that the battery has adequate reserve power to protect the connected load, charge the battery for 3 hours before putting the UPS into service.

4.1 Startup Checklist for the S4K2U-5C

Before starting the UPS, perform these checks:

1. Check that the input plugs and loads are connected properly and reliably.
2. Check that all of the battery cables are connected properly.
3. Check that the communication cables are connected properly.

4.2 Starting the UPS

1. Turn on the input circuit breaker (see Figure 2 for its location).
2. Turn on the UPS by pressing the On/Alarm Silence/Manual Battery Test button for 3 seconds.
3. Turn on the connected loads.
4. Check the status indicators to determine whether the S4K2U-5C is operating normally.
5. Check the load level indicators to verify that the connected load does not exceed the UPS's rated capacity.

The UPS is now providing conditioned power to the load.

4.3 Manual Battery Test

To initiate a manual battery test, press the On/Alarm Silence/Manual Battery Test button for at least half a second while operating from mains power with no alarm conditions present.

- If only the first two of the five LED segments illuminate, allow the UPS to recharge the batteries for 24 hours.
- Retest the batteries after 24 hours of charging the batteries.
- After the batteries have been retested, if only two of the five battery LEDs illuminate, contact your local SolaHD representative or SolaHD Technical Support.
- If none of the five battery LEDs illuminate during a manual battery test, check the battery connection and allow the UPS to recharge the batteries for 1 hour and initiate a manual battery test again.
- If none of the five battery LEDs illuminate during the manual battery test a second time, replace the batteries, and contact your local SolaHD representative or SolaHD Technical Support.

4.4 Manual Bypass

Press the Standby/Manual Bypass button once and hold it for about 2 seconds while the UPS is in Utility (V ac) Mode. The UPS will transfer the connected loads to the internal bypass. If the internal bypass is not available due to mains power problems, pressing this button once will be ignored. Bypass operation is indicated by an audible alarm and illuminated amber Bypass indicator. If other indicators are illuminated, refer to “8.0 Troubleshooting”.

4.5 Shut Down the S4K2U-5C

1. Transfer the UPS to manual bypass by pressing the Standby/Manual Bypass button once (hold it for about 2 seconds). If manual bypass is not available, disregard the first step.
2. To shut down the UPS, press the Standby/Manual Bypass button twice within 4 seconds (hold the button for about a half a second each time).

Power to the connected loads is now off.

4.6 Disconnecting Input Power from the S4K2U-5C

1. Once the UPS has been shut down as detailed in “4.5 Shut Down the S4K2U-5C”, disconnect the input cable plug.
2. Wait 30 seconds and verify that all indicators have turned off and the fan has stopped; this indicates that the power-off is complete.
3. If the UPS has an external battery cabinet, turn the external battery cabinet breaker switch to the off position.

After powering off the UPS, the UPS ceases output and the load is powered off.

5.0 Communication

This section describes UPS communication over the three types of communication connections on the rear of the S4K2U-5C.

- IntelliSlot port
- USB port (standard B-type)
- Terminal block communication

CAUTION

To maintain safety (SELV) barriers and for electromagnetic compatibility, signal cables should be segregated and run separately from all other power cables.

5.1 IntelliSlot Communication Cards

The IntelliSlot port accepts two optional cards:

- **SNMPWEB Card.** The IntelliSlot SNMPWEB Card provides SNMP monitoring and control of the UPS across the network.
- **IS-RELAY.** The IntelliSlot IS-Relay Card provides dry contact relay outputs for custom-wired applications and delivers support for built-in shutdown for AS/400 systems.

Follow the instructions provided with the IntelliSlot card to configure MultiLink, the UPS, or any additional ancillary product for the S4K2U-5C. These instructions are also available at: www.solahd.com.

5.1.1 MultiLink

MultiLink monitors the UPS continuously and can shut down your computer or server in the event of an extended power failure. MultiLink can be configured to shut down the UPS as well.

MultiLink can also be configured for use without the USB cable when the IntelliSlot SNMPWEB Card is installed in the UPS.

An optional MultiLink license kit allows you to shut down the UPS over a network. For more information about the MultiLink license kits, visit our Web site (www.solahd.com) or contact your SolaHD representative.

5.2 USB Port Communication

The standard B-type USB port is used to connect the UPS and network server or other computer system using MultiLink. The configuration program can be completed through the communication port.

5.2.1 Configuration Program

Accessing the configuration program via USB is a new feature of the S4K2U-5C. For most users, the factory default settings will be adequate. This section illustrates the features available for modification, as well as the factory default settings.

The USB configuration program allows these features of the S4K2U-5C to be changed:

- Enable/Disable Auto-Restart
- Select frequency converter operation with a fixed output frequency of 50 Hz or 60 Hz, bypass disabled
- Set the Low Battery Warning alarm time from 2 to 30 minutes
- Enable/Disable the Auto-Battery test
- Enable/Disable Auto-Restart after removing Remote Shutdown
- Set the wiring mode of Remote Shutdown
- Set the Auto-Enable output
- Set the Auto-Battery test to 7, 14, 21, or 28 days
- Select the number of external battery cabinets connected to the UPS to adjust the remaining run time calculated by software products
- Select one of multiple output voltages to match various voltages (see Table 7)

Table 7: Output Voltage Option, All Models	
Factory Default, V ac	Output Voltage Option, V ac
230	220, 230, 240

WARNING

The output voltage settings cannot be changed while the UPS is on and powering connected loads.

NOTES:

- Programming the output voltage of a 230 V model to 220 V automatically derates the UPS to 96% of both the VA and Watt ratings. Refer to “9.0 Specifications” for VA and Watt ratings.
- The configuration program is compatible with UPS models S4K2UXXXX-5C, as in S4K2U3000-5C. It is not compatible with earlier versions of the S4K2U-5 UPS.
- A computer running Windows 2000®, XP® or Vista® is required to set up and run the configuration program.

5.3 Terminal Block Communication

The terminal block includes eight pins, as shown in Figure 26.

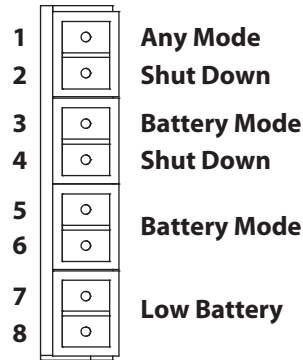

Figure 26: Terminal block layout

5.3.1 Any Mode Shutdown

The purpose of Any Mode Shutdown is to shut down the UPS output by turning off the rectifier, inverter, and static bypass switch so that there is no power to the loads.

Any Mode Shutdown can be operated locally and remotely, as described as follows:

- Local Any Mode Shutdown can be performed by shorting Pin 1 and Pin 2
- Remote Any Mode Shutdown can be performed by a switch connected to Pin 1 and Pin 2 and mounted at a remote location

NOTES:

- Remote Power off will be performed either by NO or NC contact of Any Mode Shutdown, depending on the settings in the configuration program.
- A current-limited source for the optocoupler (+12 V dc, 50 mA) will be available from the UPS.
- The connection to the UPS for remote connection will be via terminal block connector.
- Any Mode Shutdown wiring must conform to all national, regional, and local wiring regulations.

⚠ WARNING

When the Auto-Enable output option is selected and the UPS output is disabled using Pin 1 and Pin 2, the S4K2U-5C's output can turn on automatically and without warning if the Pin 1 and Pin 2 connection is changed.

5.3.2 Battery Mode Shutdown

Battery Mode Shutdown permits shutting down the UPS by turning off the rectifier, inverter, and static bypass switch so that there is no power to the load when the UPS is on battery.

Battery Mode Shutdown can be performed locally or remotely:

- Local Battery Shutdown can be performed by shorting Pin 3 and Pin 4
- Remote Battery Shutdown can be achieved by a switch connected to Pin 3 and Pin 4 and mounted at a remote location

NOTES:

- A current-limited source for the optocoupler (+12 V dc, 50 mA) will be available from the UPS.
- The connection to the S4K2U-5C for remote connection will be via terminal block connector.
- Battery mode shutdown wiring will follow local wiring codes and laws.
- This signal must last for 1.5 seconds or longer.
- A battery shutdown signal will not cause an immediate shutdown. It will start a 2 minute shutdown timer. This timer cannot be stopped once triggered. If mains power returns during this countdown, the S4K2U-5C will still shut down and must remain shut down for 10 seconds. Whether the UPS turns back on when the power is restored depends on the auto-restart setting.

5.3.3 On Battery

On Battery signal is a Normally Open (NO) dry contact. When the UPS is supplying output power from the battery this dry contact will be closed.

5.3.4 Low Battery

Low Battery signal is a Normally Open (NO) dry contact. When the UPS is supplying output power from the battery and has reached the Low Battery Warning time selected in the configuration program, this dry contact will be closed.

The dry contact rated values for the On Battery and Low Battery signals are:

- Rated Voltage: 5 V
- Working Voltage Range: 4.5–10 V
- Rated Current: 30 mA

6.0 Battery Cabinet

Optional battery cabinets are available for the S4K2U-5C. The battery port and input breaker are on the battery cabinet's rear panel, as shown in Figure 27. For battery cabinet specifications, refer to Table 12. For battery run times, refer to Table 14.

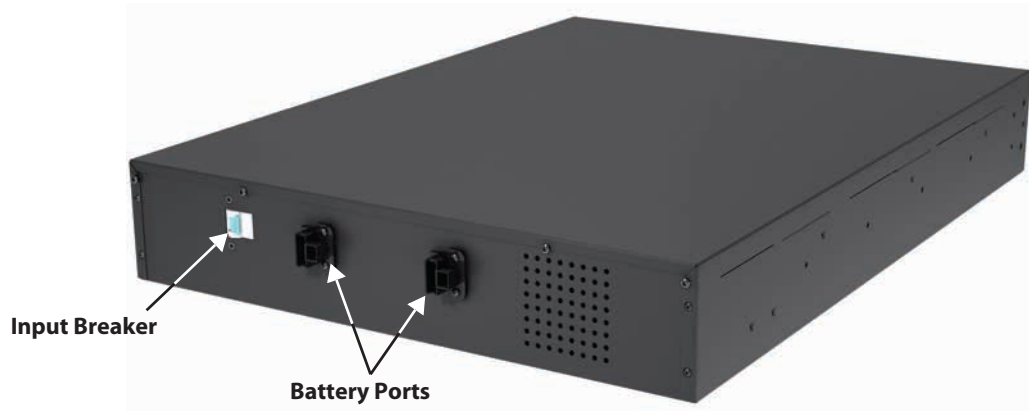

Figure 27: Battery cabinet

⚠ WARNING

Do not contact the battery ports and ground without wearing protective gloves and clothing and taking other precautions against electrical shock. The battery loop and ac input are not insulated, which may cause a dangerous voltage between the battery ports and ground.

7.0 Maintenance

This section describes replacing the internal battery pack, precautions, and checking the UPS's status and functions.

7.1 Replacing the Internal Battery Pack

The S4K2U-5C is designed to allow properly trained and qualified service personnel to replace the internal battery pack safely. Read the "Battery Safety Notes" on page 7 before proceeding. Contact your SolaHD representative to obtain the part number and pricing of the appropriate replacement battery pack. Replace batteries with the same type and number of batteries or battery packs.

⚠ CAUTION

Risk of explosion if battery is replaced by an incorrect type. Dispose of used batteries according to local regulations.

7.1.1 Battery Replacement Procedures

1. Remove the front metal bezel cover from the UPS.
2. Loosen and remove the six screws on the battery door, as shown in Figure 28.
3. Lay the battery door and screws aside for reassembly.



Figure 28: Removing the front metal bezel cover and battery door

⚠ WARNING

The battery can present a risk of electrical shock and high short circuit current. The following precautions should be observed before replacing the battery pack: (1) Remove rings, watches and other metal objects; (2) Use tools with insulated handles; (3) Do not lay tools or other metal objects on the batteries; (4) If the battery kit is damaged in any way or shows signs of leakage, contact SolaHD immediately; (5) Do not dispose of batteries in a fire; they may explode; (6) Handle, transport and recycle batteries in accordance with local regulations.

4. Gently pull the battery wire out and disconnect the polarized battery connector and receptacle, as shown in Figure 29.

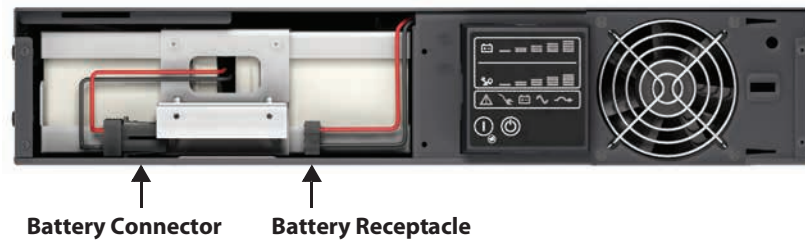

Figure 29: Disconnecting the battery connector and receptacle (front view)

5. Grasp the battery handle and pull the internal battery pack out of the UPS, as shown in Figure 30.



Figure 30: Pull out the internal battery pack

6. Unpack the new internal battery pack. Take care not to destroy the packaging. Compare the new and old internal battery packs to make sure they are the same type and model. If they are the same, proceed with Step 7; if they are different, stop and contact your local SolaHD representative or SolaHD Technical Support immediately.
7. Line up and slide in the new internal battery pack.
8. Reconnect the polarized battery connector and receptacle.
9. Gently push the battery wire and internal battery pack back into the UPS.
10. Reattach the front battery door with the six screws.
11. Reattach the front metal bezel cover to the UPS.

NOTE: The internal battery pack is hot-swappable. However, caution should be exercised during this procedure because the load is unprotected from disturbances and power outages. Do not replace the battery while the UPS is operating in Battery Mode. This will result in a loss of output power and will drop the connected load.

7.2 Battery Charging

The batteries are valve-regulated, non-spillable, lead acid and should be kept charged to attain their design life. The S4K2U-5C charges the batteries continuously when it is connected to the mains input power.

If the S4K2U-5C will be stored for a long time period of time, SolaHD recommends connecting the UPS to input power for at least 24 hours every four to six months to ensure full recharge of the batteries.

7.3 Precautions

Although the S4K2U-5C has been designed and manufactured to ensure personal safety, improper use can result in electrical shock or fire. To ensure safety, observe the following precautions:

- Turn off and unplug the S4K2U-5C before cleaning it
- Clean the UPS with a dry cloth—do not use liquid or aerosol cleaners
- Never block or insert any objects into the ventilation holes or other openings of the S4K2U-5C
- Do not place the S4K2U-5C power cord where it might be damaged

7.4 Checking UPS Status

SolaHD recommends checking the UPS operation status every six months.

- Check if the UPS is faulty: Is the Fault Indicator on? Is the UPS sounding an alarm?
- Check if the UPS is operating in Bypass Mode. Normally, the UPS operates in Normal Mode; if it is operating in Bypass Mode, stop and contact your local SolaHD representative or SolaHD Technical Support.
- Check if the battery is discharging. When the mains input is normal, the battery should not discharge. If the UPS is operating in Battery Mode, stop and contact your local SolaHD representative or SolaHD Technical Support.

7.5 Checking UPS Functions

NOTE: UPS function check procedures may interrupt power supply to the connected load. Back up all critical load data before conducting the UPS functions check.

SolaHD recommends checking the UPS functions once every six months.

Procedures are as follows:

1. Press the Standby/Manual Bypass button to check whether the buzzer and indicators are normal.
2. Press the On/Alarm Silence/Manual Battery Test button to check again whether the indicators are on and the UPS is operating normally.
3. Press the On/Alarm Silence/Manual Battery Test button for 3 seconds after Inverter Mode; the UPS should initiate battery self-test. Check to determine whether the battery is operating normally. If not, stop and contact your local SolaHD representative or SolaHD Technical Support.

8.0 Troubleshooting

This section indicates various UPS symptoms a user may encounter and troubleshooting steps in the event the UPS develops a problem. Use the following information to determine whether external factors caused the problem and how to remedy the situation.

8.1 UPS Symptoms

The following symptoms indicate the S4K2U-5C is malfunctioning:

- The relative indicators will illuminate, indicating the UPS detected a problem
- An alarm will sound, indicating that the UPS requires attention

8.1.1 Indicators

In addition to the fault indicator being illuminated, one or more of LED segments of the Battery Level indicator will also be illuminated to provide a diagnostic aid to the user, as shown in Figure 31. The descriptions are listed in Table 8.



Figure 31: Battery Level indicator

Table 8: Indicator Descriptions		
Indicator	Diagnosis	Audible Alarm
A-E	On bypass from output overload	Half-second beep every half second
A	On bypass due to overtemperature condition	1-second beep every 4 seconds
B	On bypass due to dc bus overvoltage	1-second beep every 4 seconds
C	On bypass due to dc/dc power supply failure	1-second beep every 4 seconds
D	PFC failure	1-second beep every 4 seconds
E	On bypass due to inverter failure	1-second beep every 4 seconds
A & C	UPS failed battery test	2-second beep every 60 seconds
C & E	UPS shutdown by command from communication (USB port or IntelliSlot port)	No audible alarm
A & B	UPS failure (includes dual-fan failure, single-fan failure under certain conditions, and battery charger failure)	Continuous horn
Battery indicator flashing	Internal battery source not available. Check battery connection, power down and reboot the UPS.	Continuous horn
Ac Input indicator flashing	Line-to-neutral reversal in the ac input power supply or a loss of proper grounding for the UPS. UPS cannot start in standby status.	Continuous horn
Bypass indicator flashing	Mains power voltage or frequency is out of tolerance; bypass is unavailable	n/a
Note: A-E indicators are shown in Figure 31		

8.1.2 Audible Alarm

An audible alarm will sound in conjunction with the visual indicators to indicate a change in UPS operating status. The audible alarm will sound as described in Table 9.

Condition	Alarm
Battery discharge	Half-second beep every 10 seconds
Low battery	Two half-second beeps every 5 seconds
UPS fault, load on bypass	1-second beep every 4 seconds
UPS fault, no power to load	Continuous
Overload	Half-second beep every half second
Battery replacement	2-second beep every 60 seconds
Battery loss	Continuous
Wiring problem (including line-to-neutral reversal or a loss of proper grounding for UPS)	Continuous
Bypass reminder	1-second beep every 2 minutes

8.2 Troubleshooting

In the event of an issue with the UPS, refer to Table 10 to determine the cause and solution. If the issue persists, contact SolaHD Technical Support at (800) 377-4384/(847) 268-6000 or by e-mail at solahd.technicalservices@emerson.com.

When reporting an issue to Technical Support, please include the UPS model number and serial number. This information is located on the top panel of the UPS.

Problem	Cause	Solution
UPS fails to start when the On/Alarm Silence/Manual Battery Test button is pressed	UPS is short-circuited or overloaded	Ensure the UPS is off. Disconnect all loads and ensure nothing is lodged in the output receptacles. Ensure loads are not defective or shorted internally.
Battery indicator is illuminated	UPS is not plugged in	UPS is operating from Battery Mode. Ensure UPS is securely plugged into the wall receptacle.
	UPS input protection fuse has blown/opened	UPS is operating from Battery Mode. Save data and close applications. Replace UPS input fuse, then restart the UPS.
	Mains power is out of tolerance	UPS is operating from Battery Mode. Save data and close applications. Ensure mains supply voltage is within acceptable limits for the UPS.
UPS has reduced battery time	Batteries are not fully charged	Keep the UPS plugged in continuously for at least 24 hours to recharge the batteries
	UPS is overloaded	Check Load Level indicator and reduce the load on the UPS
	Batteries may not be able to hold a full charge due to age	Replace the batteries. Contact your local dealer, SolaHD representative or SolaHD Technical Support for replacement battery packs.

Table 10: Troubleshooting		
Problem	Cause	Solution
Fault and Bypass indicators and all LED segments of the Battery Level indicator are illuminated	UPS is overloaded or the load is faulty	Check the Load Level indicator and remove non-essential loads. Recalculate the load and reduce the number of loads connected to the UPS. Check the load for faults.
Fault and Bypass indicators and Diagnostic A indicator are illuminated	UPS shutdown due to temperature conditions Load is on bypass power	Ensure the UPS is not overloaded, ventilation holes are not blocked, or room ambient temperature is not excessive. Wait 30 minutes to allow the UPS to cool, then restart the UPS. If the UPS cannot restart, contact your local dealer, SolaHD representative or SolaHD Technical Support for assistance.
Fault and Bypass indicators and Diagnostic B indicator are illuminated	UPS internal dc bus overvoltage	UPS requires service. Contact your local dealer, SolaHD representative or SolaHD Technical Support for assistance.
Fault and Bypass indicators and Diagnostic C indicator are illuminated	UPS dc/dc fault	UPS requires service. Contact your local dealer, SolaHD representative or SolaHD Technical Support for assistance.
Fault indicator and Diagnostic C indicator are illuminated	UPS PFC (Power Factor Correction Circuit) fault	UPS requires service. Contact your local dealer, SolaHD representative or SolaHD Technical Support for assistance.
Fault and Bypass indicators and Diagnostic E indicator are illuminated	UPS inverter fault	UPS requires service. Contact your local dealer, SolaHD representative or SolaHD Technical Support for assistance.
Fault indicator and Diagnostic A and C indicators are illuminated	UPS failed the battery test	Replace the batteries. Contact your local dealer, SolaHD representative or SolaHD Technical Support for replacement battery packs.
Fault and Bypass indicators and Diagnostic C and E indicator are illuminated	UPS shut down by a command from the communication port(s)	UPS has received a signal or command from the attached computer. If this was inadvertent, ensure the communication cable used is correct for your system. For assistance, contact SolaHD Technical Support.
Fault indicator and Diagnostic A and B indicators are illuminated	UPS failure (includes dual-fan failure, single-fan failure under certain conditions, and battery charger failure)	Ensure fan is not blocked up. If the fault is not resolved, contact SolaHD Technical Support for assistance.
Ac Input indicator is flashing	UPS detected a line-to-neutral reversal or a loss of proper grounding for the UPS. A continuous alarm will sound; the UPS cannot start up in standby status. This is active only when power is first applied to the input. Once the UPS is running, the Ac Input indicator will flash, unless the input wiring is correctly changed.	Contact a qualified electrician to verify site wiring.
Battery indicator is flashing	Battery source is not available	Check battery connections, completely power down and restart the UPS. NOTE: If the battery circuit opens while the UPS is running, it will be detected when the next battery test is performed.
Bypass indicator is flashing	The bypass is disabled because the voltage or frequency is outside the acceptable limits	The ac input powers the PFC input and serves as the bypass source. If the ac is present but the voltage or frequency exceeds the acceptable range for safe operation with a load, the bypass will be disabled and this indicator will flash, indicating that the bypass is unavailable.

9.0 Specifications

Table 11: UPS Specifications			
Parameters	Model		
	S4K2U1000-5C	S4K2U2000-5C	S4K2U3000-5C
DIMENSIONS, D x W x H, mm [in.]			
Unit	497 x 430 x 85 [19.6 x 16.9 x 3.3]		602 x 430 x 85 [23.7 x 16.9 x 3.3]
Shipping	717 x 570 x 262 [28.2 x 22.4 x 10.3]		717 x 570 x 262 [28.2 x 22.4 x 10.3]
WEIGHT, kg [lb.]			
Unit	16.8 [37.0]	23.2 [51.1]	32.4 [71.4]
Shipping	20.0 [44.1]	26.0 [57.3]	36.0 [79.4]
INPUT AC PARAMETERS			
Voltage range (typical)	230 V ac nominal; variable based on output load		
90% to 100% Loading	177 V ac/280 V ac		196 V ac/280 V ac
70% to 90% Loading	168 V ac/280 V ac		184 V ac/280 V ac
30% to 70% Loading	150 V ac/280 V ac		161 V ac/280 V ac
0% to 30% Loading	115 V ac/280 V ac		115 V ac/280 V ac
Power factor	0.99		
Frequency	40 Hz to 70 Hz; auto sensing		
Input power receptacle	IEC 320 C14	IEC 320 C20	
OUTPUT AC PARAMETERS			
Output receptacles	IEC 320 C13 x 6		IEC 320 C13 x 6; IEC 320 C19 x 1
Voltage	208/220/230/240 V ac (user-configurable) ±3%		
Frequency	50 Hz or 60 Hz		
Waveform	Sine wave		
Overload	200% for 2 seconds; 150% for 1 minute with transfer to bypass	200% for 2 seconds; 150% for 50 seconds with transfer to bypass	200% for 2 seconds; 150% for 55 seconds with transfer to bypass
Power factor	0.90		
BATTERY			
Type	Valve-regulated, non-spillable, lead acid		
Qty x V x Rating	4 x 12 V x 5.0 Ah	4 x 12 V x 9.0 Ah	6 x 12 V x 9.0 Ah
Battery mfr./Part number	Panasonic/UP-RW1245; CSB/HR 1234W F2		
Backup time	See Table 14		
Recharge time	3 hours to 90% capacity after full discharge with 100% load until UPS auto shutdown (internal batteries only)		
ENVIRONMENTAL REQUIREMENTS			
Operating temperature	0°C to +40°C [+32°F to +104°F]; see Table 13 for operating temperature parameters		
Storage temperatures	-15°C to +50°C [+5°F to +122°F]		
Relative humidity	0% to 95%, non-condensing		
Operating elevation	Up to 3,000 m [10,000 ft.]		

Table 11: UPS Specifications			
Parameters	Model		
	S4K2U1000-5C	S4K2U2000-5C	S4K2U3000-5C
Storage elevation	15,000 m [50,000 ft.] max.		
Audible noise	<43 dBA max. @ 1 m [3 ft.] front & sides; <46 dBA max. @ 1 m [3 ft.] rear	<48 dBA max. @ 1 m [3 ft.] front & sides; <48 dBA max. @ 1 m [3 ft.] rear	
AGENCY			
Safety	EC/EN/AS 62040-1-1:2008		
RFI/EMI	IEC/EN/AS 62040-2 2 nd Ed. = CISPR22 Class A		
Surge immunity	IEC62040-2 2 nd Ed.		
Transportation	ISTA Procedure 1A		

Table 12: Battery Cabinet Specifications		
Parameters	Model Number	
	S4K2U48BATC	S4K2U96BATC
Used with UPS models	S4K2U1000-5C, S4K2U2000-5C	S4K2U3000-5C
DIMENSIONS, D x W x H, mm [in.]		
Unit	497 x 430 x 85 [19.6 x 16.9 x 3.3]	602 x 430 x 85 [23.7 x 16.9 x 3.3]
Shipping	717 x 570 x 262 [28.2 x 22.4 x 10.3]	717 x 570 x 262 [28.2 x 22.4 x 10.3]
WEIGHT, kg [lb.]		
Unit	32.0 [70.5]	42.4 [93.5]
Shipping	35.0 [77.2]	46.0 [101.4]
BATTERY PARAMETERS		
Type	Valve-regulated, non-spillable, lead acid	
Qty x V x Rating	2 x 4 x 12 V x 9.0 Ah	2 x 6 x 12 V x 9.0 Ah
Battery mfr./Part number	Panasonic/UP-RW1245; CSB/HR 1234W F2	
Backup time	See Table 14	
ENVIRONMENTAL REQUIREMENTS		
Operating temperature	0°C to +40°C [+32°F to +104°F]; see Table 13 for operating temperature parameters	
Storage temperatures	-15°C to +50°C [+19°F to +104°F]	
Relative humidity	0% to 95%, non-condensing	
Operating elevation	Up to 3,000 m [10,000 ft.]	
Storage elevation	15,000 m [50,000 ft.] max.	
AGENCY		
Safety	EC/EN/AS 62040-1-1:2008	
RFI/EMI	IEC/EN/AS 62040-2 2 nd Ed. = CISPR22 Class A	
Surge immunity	IEC62040-2 2 nd Ed.	
Transportation	ISTA Procedure 1A	

Table 13: Operating Temperature Parameters			
Ambient temperature	+25°C to +30°C [+77°F to +86°F]	+30°C to +35°C [+86°F to +95°F]	+35°C to +40°C [+95°F to +104°F]
Maximum output power factor derating at maximum load	100% to 93%	93% to 86%	86% to 79%

Table 14: Battery Backup Times				
Number of Batteries/Cabinets	Load % of Capacity	Model Rating		
		1000 VA	2000 VA	3000 VA
		Backup Time in Minutes		
Internal battery	10%	91	73	77
	20%	38	33	37
	30%	31	21	21
	40%	23	15	15
	50%	17	11	11
	60%	14	8	8
	70%	11	6	6
	80%	9	5	5
	90%	8	4	4
Internal battery + 1 external battery cabinet	10%	214	166	182
	20%	153	121	123
	30%	124	79	79
	40%	100	41	53
	50%	79	38	46
	60%	66	34	38
	70%	41	30	31
	80%	38	25	26
	90%	36	21	21
Internal battery + 2 external battery cabinets	10%	337	306	311
	20%	216	159	160
	30%	166	133	134
	40%	152	105	105
	50%	136	81	81
	60%	121	67	68
	70%	104	40	52
	80%	93	38	47
	90%	79	36	43
Internal battery + 3 external battery cabinets	10%	480	331	335
	20%	322	202	205
	30%	219	157	157
	40%	191	138	139
	50%	161	120	120
	60%	151	99	100
	70%	140	80	81
	80%	128	70	71
	90%	112	60	62
Internal battery + 4 external battery cabinets	10%	480	346	480
	20%	340	301	303
	30%	316	186	187
	40%	220	156	156
	50%	198	141	141
	60%	166	126	127
	70%	158	107	108
	80%	149	95	97
	90%	141	79	81
	100%	133	72	73

10.0 Warranty & Support

10.1 Warranty Information

Please see the “Terms & Conditions of Sale”.

10.2 Technical Support

Phone: (800) 377-4384 or (847) 268-6651

E-mail: solahd.technicalservices@emerson.com

Web site: www.solahd.com

SolaHD • 1.800.377.4384 (US) • 1.847.268.6651 (International) • www.solahd.com